

PowerDrain - S100K iron edged channels

One meter channel

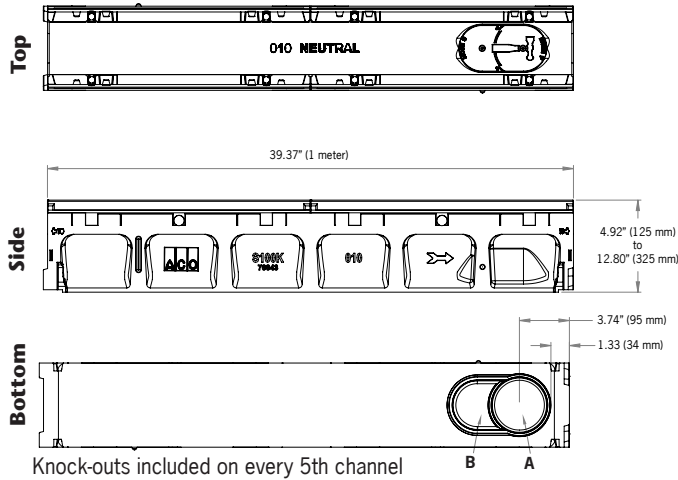

Half meter channel

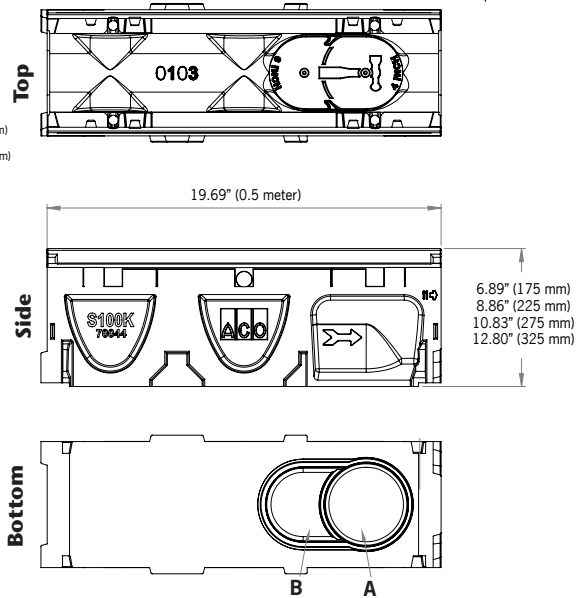

Type 901D In-line catch basin

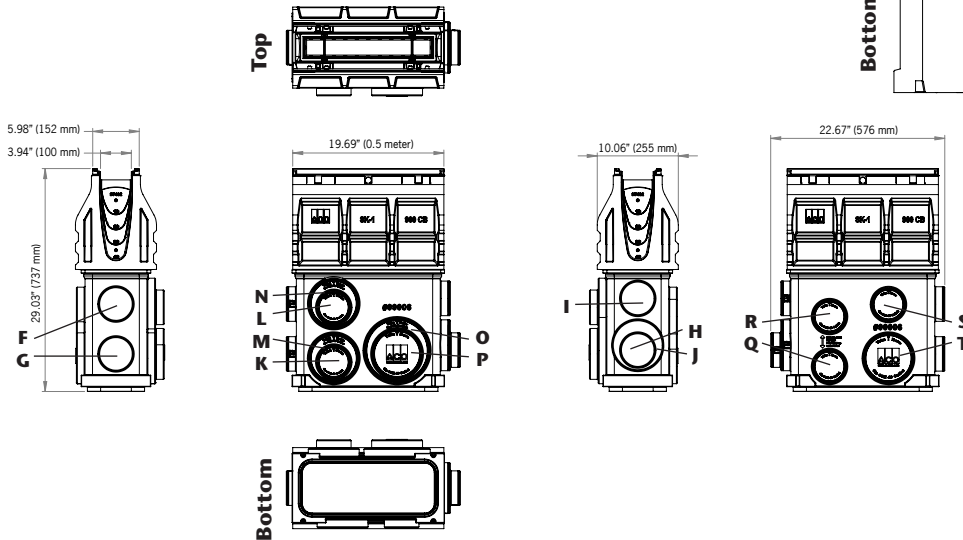

Total capacity = 10.49 gallons.

Outlet flow rates

Outlet	Product	Outlet size (Sch. 40)	Invert Depth	GPM	CFS
A	Bottom outlet - SK1-00	4" round	3.94"	108	0.24
A	Bottom outlet - SK1-40	4" round	11.81"	187	0.42
B	Bottom outlet - SK1-00	6" oval	3.94"	177	0.39
B	Bottom outlet - SK1-40	6" oval	11.81"	306	0.68
C	End outlet - SK1-20	4" round	7.87"	132	0.29
C	End outlet - SK1-40	4" round	11.81"	171	0.38
D	SK1-308-6 6" outlet cap	6" oval	9.84"	233	0.52
E	SK1-408-6 6" outlet cap	6" oval	11.81"	264	0.59
F	Type SK1-901D	4" round	19.87"	230	0.51
G	Type SK1-901D	4" round	26.37"	268	0.60
H	Type SK1-901D	4" round	25.87"	266	0.59
I	Type SK1-901D	4" round	19.16"	226	0.50
J	Type SK1-901D	6" round	26.29"	593	1.32
K	Type SK1-901D	4" round	27.22"	272	0.61
L	Type SK1-901D	4" round	20.11"	231	0.51
M	Type SK1-901D	6" round	27.79"	611	1.36
N	Type SK1-901D	6" round	20.65"	514	1.15
O	Type SK1-901D	8" round	27.79"	1065	2.37
P	Type SK1-901D	6" round	27.22"	601	1.34
Q	Type SK1-901D	4" round	27.79"	276	0.62
R	Type SK1-901D	4" round	21.30"	239	0.53
S	Type SK1-901D	4" round	19.73"	228	0.51
T	Type SK1-901D	6" round	27.79"	610	1.36

Note: These are the pipe flow rates at the specified outlet, NOT channel flow rates. Catch basin flow rates are without trash bucket - using trash bucket reduces flow.

End Caps

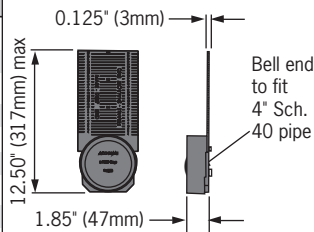

6" Oval inlet cap

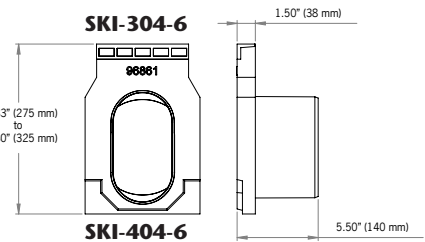

6" Oval outlet cap

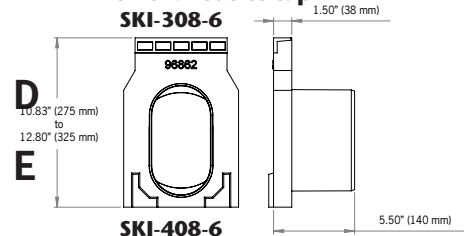

Supplied By:



877-903-7246

www.trenchdrainsupply.com

www.ACODrain.us



ACO Specification Information





PowerDrain - S100K iron edged channels

ACO Specification Information

Description	Part No.	Invert Inches ²	mm ²	Weight lbs.
SK1-00 Neutral channel - 39.37" (1m)^D	67041	3.94	100	48.1
SK1-1 Sloped channel - 39.37" (1m)	67001	4.13	105	48.1
SK1-2 Sloped channel - 39.37" (1m)	67002	4.33	110	49.1
SK1-3 Sloped channel - 39.37" (1m)	67003	4.53	115	50.1
SK1-4 Sloped channel - 39.37" (1m)	67004	4.72	120	51.1
SK1-5 Sloped channel - 39.37" (1m) ^D	67005	4.92	125	52.1
SK1-6 Sloped channel - 39.37" (1m)	67006	5.12	130	53.1
SK1-7 Sloped channel - 39.37" (1m)	67007	5.31	135	54.1
SK1-8 Sloped channel - 39.37" (1m)	67008	5.51	140	55.1
SK1-9 Sloped channel - 39.37" (1m)	67009	5.71	145	56.1
SK1-10 Sloped channel - 39.37" (1m) ^D	67010	5.91	150	57.1
SK1-010 Neutral channel - 39.37" (1m)^D	67043	5.91	150	57.1
SK1-0103 Neutral channel - 19.69" (0.5m)^D	67044	5.91	150	29.4
SK1-11 Sloped channel - 39.37" (1m)	67011	6.10	155	58.1
SK1-12 Sloped channel - 39.37" (1m)	67012	6.30	160	59.1
SK1-13 Sloped channel - 39.37" (1m)	67013	6.50	165	60.1
SK1-14 Sloped channel - 39.37" (1m)	67014	6.69	170	61.1
SK1-15 Sloped channel - 39.37" (1m) ^D	67015	6.89	175	62.1
SK1-16 Sloped channel - 39.37" (1m)	67016	7.09	180	63.1
SK1-17 Sloped channel - 39.37" (1m)	67017	7.28	185	64.1
SK1-18 Sloped channel - 39.37" (1m)	67018	7.48	190	65.1
SK1-19 Sloped channel - 39.37" (1m)	67019	7.68	195	66.1
SK1-20 Sloped channel - 39.37" (1m) ^D	67020	7.87	200	67.1
SK1-020 Neutral channel - 39.37" (1m)^D	67045	7.87	200	67.1
SK1-0203 Neutral channel - 19.69" (0.5m)^D	67046	7.87	200	33.9
SK1-21 Sloped channel - 39.37" (1m)	67021	8.07	205	68.10
SK1-22 Sloped channel - 39.37" (1m)	67022	8.27	210	69.10
SK1-23 Sloped channel - 39.37" (1m)	67023	8.46	215	70.0
SK1-24 Sloped channel - 39.37" (1m)	67024	8.66	220	71.0
SK1-25 Sloped channel - 39.37" (1m) ^D	67025	8.86	225	72.0
SK1-26 Sloped channel - 39.37" (1m)	67026	9.06	230	73.0
SK1-27 Sloped channel - 39.37" (1m)	67027	9.25	235	74.0

Description	Part No.	Invert Inches ²	mm ²	Weight lbs.
SK1-28 Sloped channel - 39.37" (1m)	67028	9.45	240	75.0
SK1-29 Sloped channel - 39.37" (1m)	67029	9.65	245	76.0
SK1-30 Sloped channel - 39.37" (1m) ^D	67030	9.84	250	77.00
SK1-030 Neutral channel - 39.37" (1m)^D	67047	9.84	250	77.00
SK1-0303 Neutral channel - 19.69" (0.5m)^D	67048	9.84	250	38.4
SK1-31 Sloped channel - 39.37" (1m)	67031	10.04	255	78.0
SK1-32 Sloped channel - 39.37" (1m)	67032	10.24	260	79.0
SK1-33 Sloped channel - 39.37" (1m)	67033	10.43	265	80.0
SK1-34 Sloped channel - 39.37" (1m)	67034	10.63	270	81.0
SK1-35 Sloped channel - 39.37" (1m) ^D	67035	10.83	275	82.0
SK1-36 Sloped channel - 39.37" (1m)	67036	11.02	280	83.0
SK1-37 Sloped channel - 39.37" (1m)	67037	11.22	285	84.0
SK1-38 Sloped channel - 39.37" (1m)	67038	11.42	290	85.0
SK1-39 Sloped channel - 39.37" (1m)	67039	11.61	295	86.0
SK1-40 Sloped channel - 39.37" (1m) ^D	67040	11.81	300	87.0
SK1-040 Neutral channel - 39.37" (1m)^D	67049	11.81	300	87.0
SK1-0403 Neutral channel - 19.69" (0.5m)^D	67050	11.81	300	43.0
SK1-901D In-line catch basin - 19.69" (0.5m) ^D	67051	28.23	717	86.0
SK1-621D catch basin - 19.69" (0.5m) ^D	67053	28.86	733	75.7
SK1-631D catch basin - 19.69" (0.5m) ^D	67054	40.86	1038	85.7
Series 600 optional riser	99902	-	-	10.0
Foul air trap - fits both 900 & 600 basins	90854	-	-	1.2
SK1-304-6 6" Inlet Cap	96861	9.84	250	6.2
SK1-308-6 6" Outlet Cap	96862	9.84	250	6.0
SK1-404-6 6" Inlet Cap	96863	11.81	300	7.2
SK1-408-6 6" Outlet Cap	96864	11.81	300	7.0
SK1-Universal end cap	96824	11.81	300	0.4
Debris strainer for 4" bottom knockout	93488	-	-	0.2
4" Oval to 6" round outlet adaptor	95140	-	-	1.1
4" Installation device	97477	-	-	2.8
Grate removal tool	01318	-	-	0.3
SK1 ductile iron slotted grate [®]	96082	-	-	12.3
SK1 ductile iron longitudinal grate [®]	96096	-	-	13.6

Notes:

1. This channel offers bottom knockout feature; 4" round/6" oval.
2. Inverts shown are male end; for female invert depth subtract 5mm (≈0.2") from male invert (except neutral channels where it will be same as male invert).
To calculate overall channel depth add 25.4mm (≈1") to invert depth.
3. Catch basin assembly includes polymer concrete top, trash bucket and plastic base.
4. Catch basin assembly includes polymer concrete top, deep trash bucket, plastic riser and plastic base.
5. Water intake per meter channel is 50.4 in² (325.16 cm²).
6. See 4" width ductile iron grate specification info for grate details.

Specifications		Frost proof	YES	edge rail shall be at least 1/4" (6mm) thick.
General		Salt proof	YES	Installation The trench drain system shall be installed in accordance with the manufacturer's installation instructions and recommendations.
		Dilute acid and alkali resistant	YES	
		The nominal clear opening shall be 4" (100mm) with overall width of 6.30" (160mm). Pre-cast units shall be manufactured with either an invert slope of 0.5% or with neutral invert and have a wall thickness of at least 0.67" (16mm). Each unit will feature a partial radius in the trench bottom and a male to female interconnecting end profile. Units shall have horizontal cast in anchoring keys on the outside wall to ensure maximum mechanical bond to the surrounding bedding material and pavement surface. The ductile iron edge rail will be integrally cast in by the manufacturer to ensure maximum homogeneity between polymer concrete body and edge rail. Each		
Materials				
The trench system bodies shall be manufactured from polyester polymer concrete with minimum properties as follows:				
Compressive strength:	14,000 psi			
Flexural strength:	4,000 psi			
Water absorption	0.07%			

ACO Polymer Products, Inc.

Northeast Sales Office
9470 Pinecone Dr.
Mentor, OH 44060
Tel: (440) 639-7230
Toll free: (800) 543-4764
Fax: (440) 639-7235

West Sales Office
825 W. Beechcraft St.
Casa Grande, AZ 85122
Tel: (520) 421-9988
Toll Free: (888) 490-9552
Fax: (520) 421-9899

Southeast Sales Office
4211 Pleasant Road
Fort Mill, SC 29708
Toll free: (800) 543-4764
Fax: (803) 802-1063

Follow us on



Electronic Contact:
info@ACODrain.us
www.ACODrain.us



© Feb 11, 2016 ACO Polymer Products, Inc. This information is believed to be accurate but it is not guaranteed to be so. We cannot assume liability for results that buyer obtains with our product since conditions of use are beyond the control of the company. It is the customer's responsibility to evaluate suitability and safety of product for his own use. ACO Polymer Products Inc. reserves the right to change the product and specifications without notice.